



## Power Steering System Purging

### Special Tool(s)

 <p>ST2670-A</p>	Evacuation Cap, Power Steering 211-265
 <p>ST1176-A</p>	Vacuum Pump Kit 416-D002 (D95L-7559-A) or equivalent

### Material

Item	Specification
MERCON® V Automatic Transmission Fluid XT-5-QM (or XT-5-QMC) (US); CXT-5- LM12 (Canada)	MERCON® V

**NOTICE:** If the air is not purged from the power steering system correctly, premature power steering pump failure may result. The condition may occur on pre-delivery vehicles with evidence of aerated fluid or on vehicles that have had steering component repairs.

1. **NOTE:** A whine heard from the power steering pump can be caused by air in the system. The power steering purge procedure must be carried out prior to any component repair for which power steering noise complaints are accompanied by evidence of aerated fluid.

Remove the power steering reservoir cap. Check the fluid.

2. Raise the front wheels off the floor. Refer to the appropriate section in Group [100](#) for the procedure.
3. Tightly insert the Power Steering Evacuation Cap into the reservoir and connect the Vacuum Pump Kit.

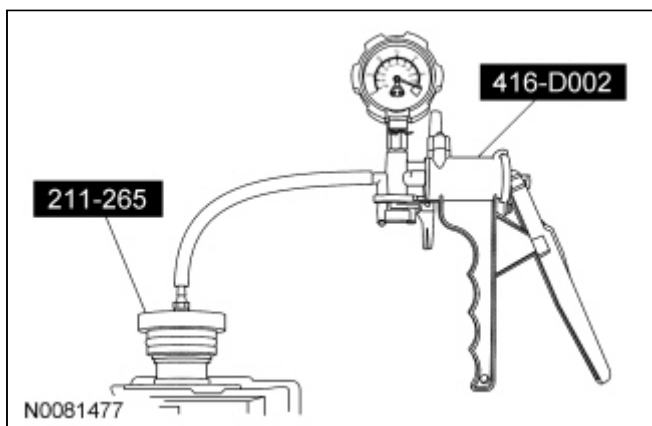

4. Start the engine.

5. Using the Vacuum Pump Kit, apply vacuum and maintain the maximum vacuum of 68-85 kPa (20-25 in-Hg).
  - If the Vacuum Pump Kit does not maintain vacuum, check the power steering system for leaks before proceeding. For additional information, refer to Power Steering Fluid Leak Test in this section.

6. If equipped with Hydro-Boost®, apply the brake pedal 4 times.

7. **NOTICE: Do not hold the steering wheel against the stops for an extended amount of time. Damage to the power steering pump may occur.**

Cycle the steering wheel fully from stop-to-stop 10 times.

8. Stop the engine.

9. Release the vacuum and remove the Vacuum Pump Kit and the Power Steering Evacuation Cap.

10. **NOTE:** Do not overfill the reservoir.

Fill the reservoir as needed with the specified fluid.

11. Start the engine.

12. Install the Power Steering Evacuation Cap and the Vacuum Pump Kit. Apply and maintain the maximum vacuum of 68-85 kPa (20-25 in-Hg).

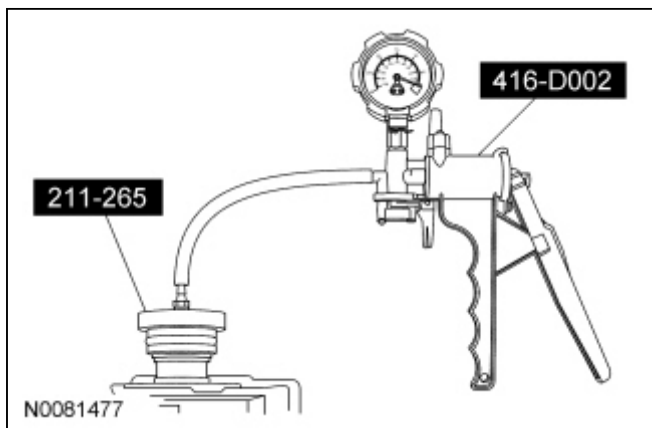

13. **NOTICE: Do not hold the steering wheel against the stops for an extended amount of time. Damage to the power steering pump may occur.**

Cycle the steering wheel fully from stop-to-stop 10 times.

14. Stop the engine, release the vacuum and remove the Vacuum Pump Kit and the Power Steering Evacuation Cap.

15. **NOTE:** Do not overfill the reservoir.

Fill the reservoir as needed with the specified fluid and install the reservoir cap.

16. Visually inspect the power steering system for leaks.

---

